



# Medical Stretcher & Attendant Seating





## Piper PA31 Navajo & PA42 Cheyenne Stretcher





## Piper PA31 Navajo & PA42 Cheyenne Stretcher







# Piper PA31 & PA 42 Stretcher

**Description:** This stretcher kit provides a Piper PA-31 Navajo or PA-42 Cheyenne Stretcher operator with the option of transporting an ill or non-critical patient. The kit was designed as an economical alternative to complete medevac systems. This unit is ideal for those operators who don't need critical care medical equipment.

**Models:** Piper PA31 Navajo and PA42 Cheyenne

**FAA / STC:** SA00961WI

**Approval:** Federal Aviation Administration Parts Manufacture Approval, PMA, and Supplemental Type Certificate, STC, (eliminating the need for field approval).

**Features:** Kit includes stretcher base and cover, Ferno 12-1 portable litter, mattress, mattress cover (conforms to FAR 23.853 horizontal flame test), restraint system, installation instructions, and weight and balance data, etc.

**Installation:** Initial installation can be accomplished by simply removing the seats on the applicable side of the aircraft and sliding the stretcher on existing seat rails..

**Lead Time:** Stretchers are normally in stock and available for immediate world-wide shipment, however, fluctuations in demand may cause up to a 30 day delivery delay.





# Piper Stretcher

## Line Drawing with Litter Detail

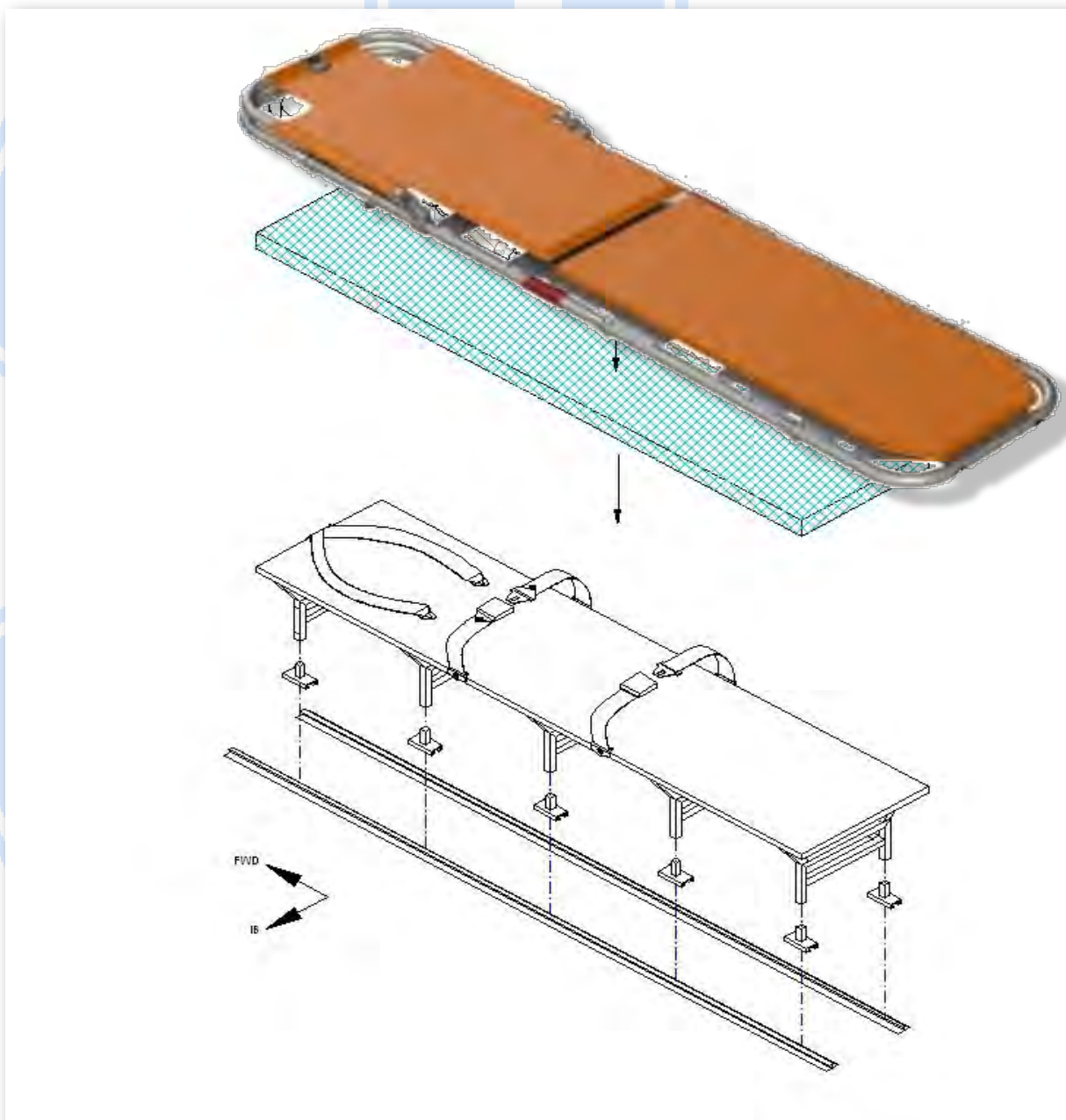



## Piper PA31 / PA42 Attendant Seating 2-Place Divan

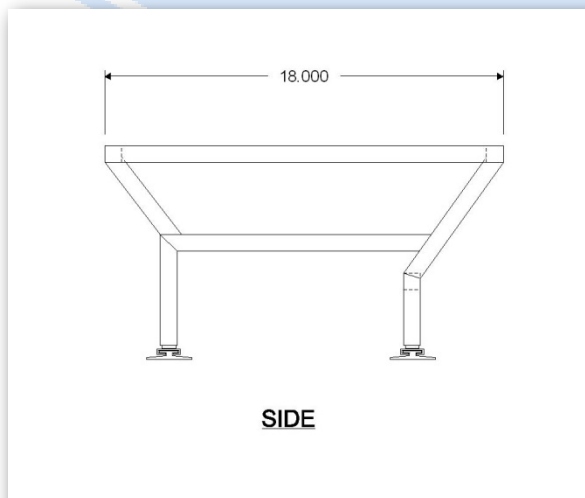
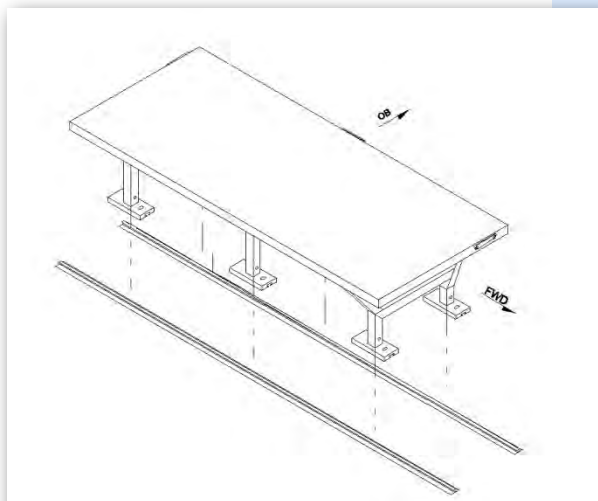



## PA32 & PA34 Stretcher





## PA32 & PA34 Stretcher

**Description:** This stretcher kit provides a Piper PA32 Cherokee Six / Lance / Saratoga or PA34 Seneca operator with the option of transporting an ill or non-critical patient. The kit was designed as an economical alternative to complete medevac systems. This unit is ideal for those operators who don't need critical care medical equipment.

**Models:** PA32 Cherokee Six / Lance / Saratoga or PA34 Seneca

**FAA / STC:** SA1310SW

**Approval:** Federal Aviation Administration Parts Manufacture Approval, PMA, and Supplemental Type Certificate, STC, (eliminating the need for field approval).

**Features:** Kit includes stretcher base and cover, mattress, mattress cover (conforms to FAR 23.853 horizontal flame test), restraint system, installation instructions, and weight and balance data, etc.

**Installation:** No airframe modification is required other than removing existing seat/s and furnishings, and setting the new stretcher assembly in the existing floor fittings which were vacated by the removed seats (complete installation instructions, diagrams, and weight and balance data are included in the kit).

**Lead Time:** Stretchers are normally in stock and available for immediate world-wide shipment, however, fluctuations in demand may cause up to a 30 day delivery delay.







## PA32/PA34 Line Drawing with Litter Detail

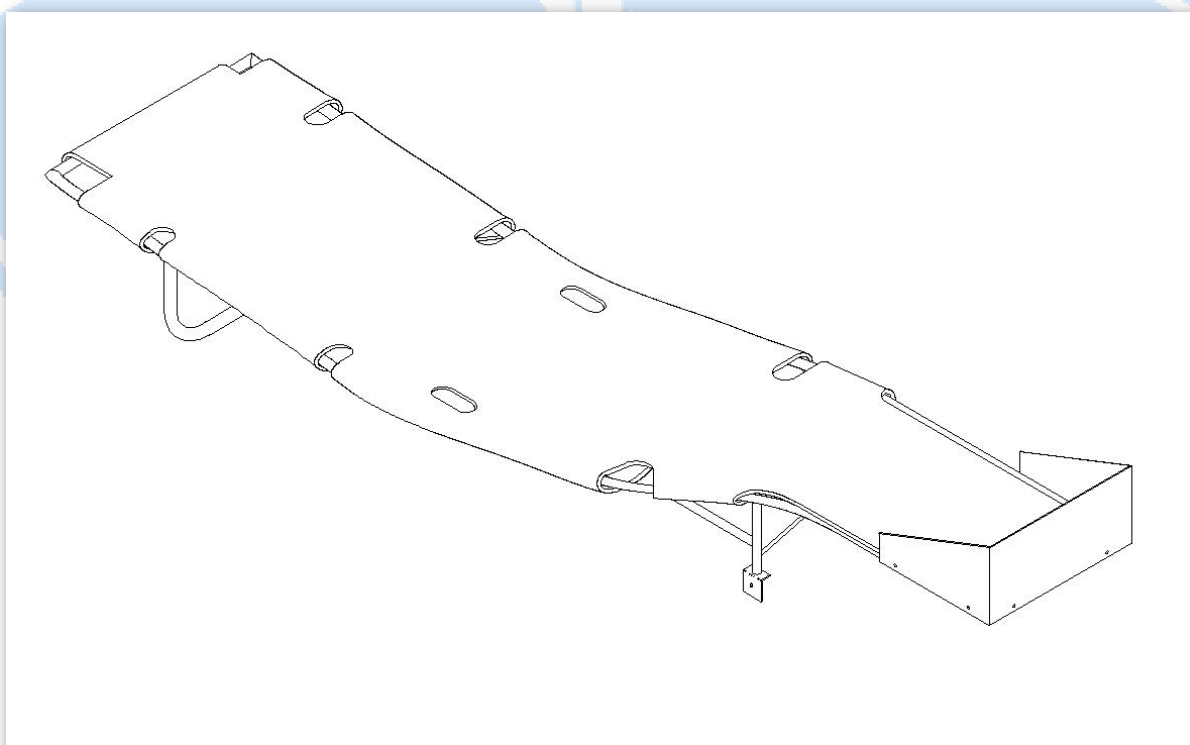
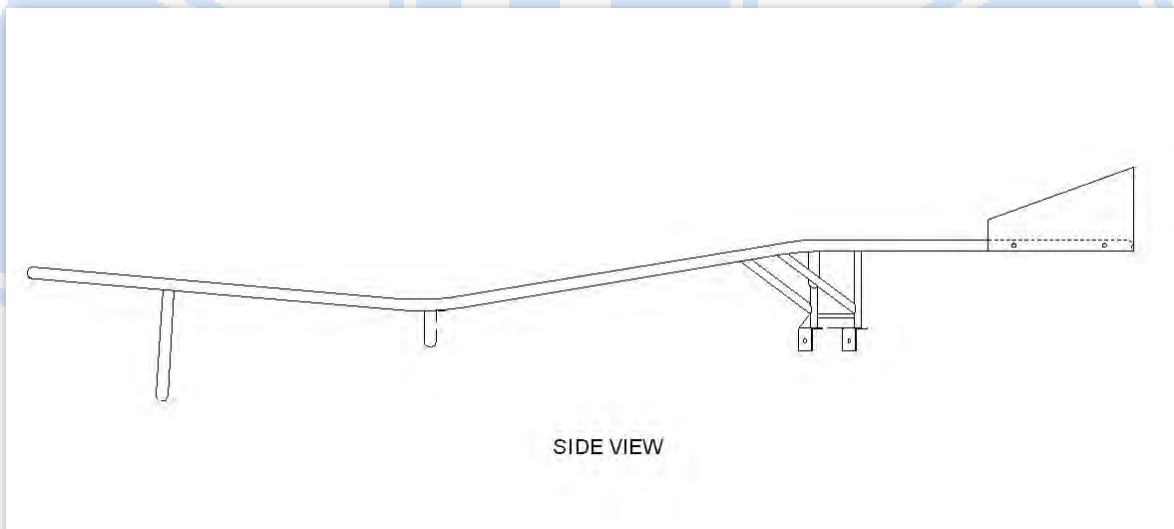



Learn more about Avfab's comprehensive  
line of products & services at:  
**[www.AvFab.com](http://www.AvFab.com)**



**Aviation Fabricators**  
805 North Forth Street  
Clinton, MO 64735  
(660) 885-8317  
**[www.AvFab.com](http://www.AvFab.com)**

**25** YEARS OF  
AVIATION  
PASSION

